

APPLICATIONS

- Directional wave measurement
- Currents and tides
- Nearshore deployments
- Bottom boundary and turbulence
- Sediment accumulation/erosion

FEATURES

- High accuracy single-point current meter
- AutoVelocity processing
- Distance to boundary
- Compact, lightweight and ready-to-deploy
- Affordable

Combining the power of SonTek's ADV[®] technology with the proven PUV wave method, the Triton is the most value-packed system available for currents, directional waves and tides. In a single package you'll get the high-accuracy velocity data that SonTek is known for, coupled with integrated pressure, temperature and compass/tilt sensors in a ready-to-deploy system. SonTek's ViewTriton software makes processing and analyzing your data a breeze!

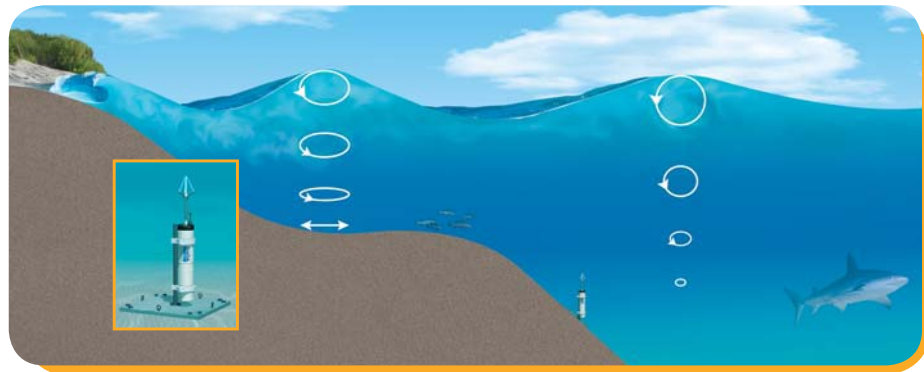

An illustration depicting typical environments where a Triton-ADV can be deployed.



A Triton-ADV being used for directional wave and current measurement in seepage study.

AutoVelocity prevents velocity "wrapping" (i.e. ambiguity jumps)

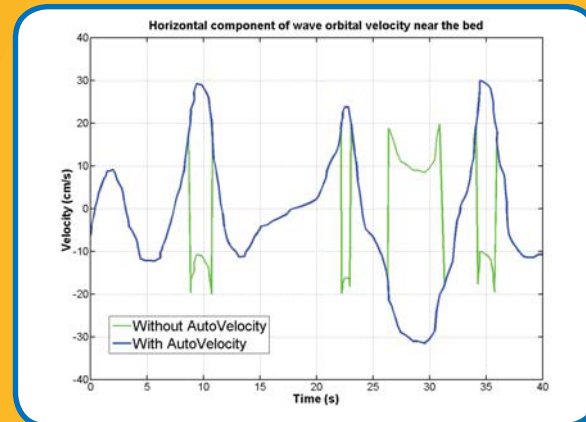

SonTek's proprietary AutoVelocity processing automatically corrects for velocity wrapping that can be found in other acoustic Doppler velocimeters.



SPECIFICATIONS

Triton-ADV

Standard Features

- SonTek *AutoVelocity* range capability
- Remote sampling volume of 0.25 cc located 10 cm from center transducer
- Integrated pressure and temperature sensors
- Distance to boundary
- 128 MB CompactFlash memory (up to 1 GB optional)
- Internal battery pack
- Windows software for data analysis, processing and exporting, including processing of directional wave data using proven PUV method
- Solid state compass/tilt sensor

Velocity Specifications

- Range: ± 0.1 to 4.8 m/s
- Resolution: 0.01 cm/s
- Accuracy: $\pm 1\%$ of measured velocity, ± 0.1 cm/s
- AutoVelocity ranges: up to 480 cm/s
- Four preset (fixed) ranges: ± 15 , 50, 200 or 480 cm/s

Wave Sampling Specifications

- Sampling rate up to 4 Hz for fixed velocity range
- 2 Hz for AutoVelocity range
- Series length: 128 to 8192 samples

Compass Specifications

- SonTek solid state TrueCompass
- Full 360° operation
- Heading accuracy: 1.5° RMS
- Tilt accuracy: 0.5° RMS

Temperature Specifications

- Accuracy: 0.1 °C
- Resolution: 0.01 °C

Pressure Specifications (range 30 m)

- Type: Piezoresistive (strain gauge)
- Accuracy: 0.1%

Power Requirements

- 7-15 VDC
- Consumption:
 - Velocity only: 0.2 to 0.5 W
 - Velocity + Waves: 1.2 to 1.5 W
 - Sleep mode: 0.001 W
- Typical deployment length: 1-3 months, depending on system configuration
- Nominal battery capacity: 220 W-h
- Optional 500 W-h external battery pack (triples deployment length)

Environmental

- Depth rating: 60 m (pressure sensor dependent)
- Operating temp: -5 to 40 °C
- Storage temperature: -10 to 50 °C
- Weight in air: 3.2 kg (7 lbs)
- Weight in water: 0.45 kg (1 lb)

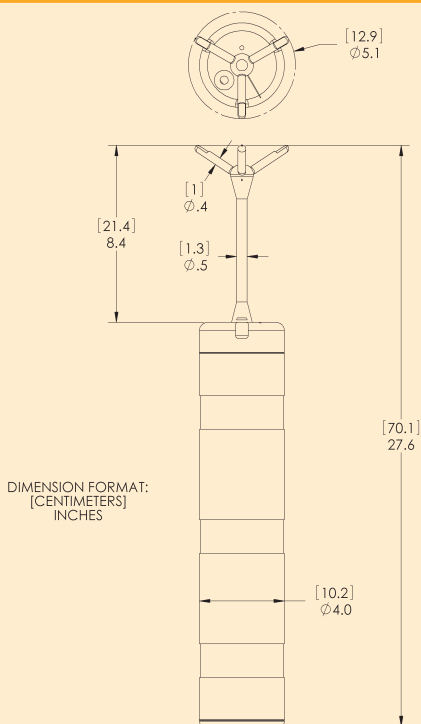

SOFTWARE

Tides

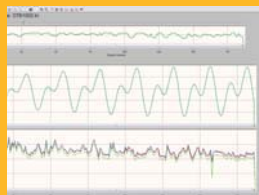

Currents

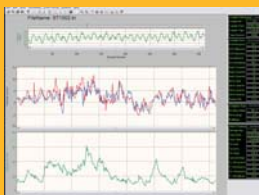

Waves

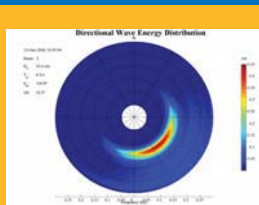

Certificate Number: 160263
BS EN ISO 9001 : 2000

Sea and Land Technologies Pte Ltd

65 Tuas Avenue 1
Singapore 639508
Email: enquiry@sea-landtech.com.sg
Website: http://www.sea-landtech.com.sg

Tel : +(65) 6518 0777
Fax : +(65) 6563 0366



A Triton-ADV ready for deployment off La Jolla, California.

SonTek and ADV are registered trademarks of SonTek/YSI, San Diego CA, USA.
Specifications subject to change without notice. SonTek/YSI is an employee-owned company.
Lit: S02-03 0307. Seepage study photo courtesy of Steve Krupa, SFWMD.



Sound Principles. Good Advice.

www.sontek.com