



Super SeaPrince DST

Features

- Digital CHIRP Sonar system
- True acoustic zoom
- Instant scan reversal
- Forward Looking Sonar, 360 Degree Sonar and Sector Scan Sonar Modes
- Inverted Sonar head operation
- Optional depth rated to 4000m
- Available in single or dual port housing
- Option of ArcNet and single head RS232 or RS485 communications

Applications

- Specifically designed for medium sized survey, observation and light work class ROV
- AUV / ROV obstacle avoidance and target recognition sonar
- Harbour, port and asset surveillance



The Tritech Super SeaPrince DST (Digital Sonar Technology) is an all-new sonar incorporating everything that we have learnt from previous generations of SeaPrince Sonars and the industry standard SeaKing and Micron DST sonars.

The Super SeaPrince DST Sonar is designed specifically for survey, observation and light work class ROV. The sonar is a single transducer, full digital CHIRP system, complementing the larger dual transducer Super SeaKing DST Sonar.

This core product sets new standards in sonar technology; its advanced composite transducer and CHIRP signal processing generate images of unprecedented clarity and resolution.

The Super SeaPrince DST is available in two configurations with either single or dual port pressure housings. This enables the sonar to function within the ArcNet network and interface with Tritech and third party products.

The standard depth rating of a Super SeaPrince DST Sonar is 4000 meters. It has all the functionality expected of a Tritech professional offshore sonar. Amongst its advanced capabilities are instant scan reversal, sector scan, image measurement, inverted head operation and true acoustic zoom.

The Super SeaPrince DST sonar CHIRPs around its optimised frequency of 675kHz. The sonar is extremely rugged, built to the highest quality standards and with a hard boot to protect the transducer.

The Super SeaPrince DST Sonar may be operated by the Tritech Surface Control Unit (SCU) or a customer supplied PC or laptop. As part of the SeaKing family, the sonar can be run simultaneously with other SeaKing products on a single ArcNet communications link, using the same processor and display. The sonar can also be configured for either RS232 or RS485 protocols.



Single port housing



Dual port housing

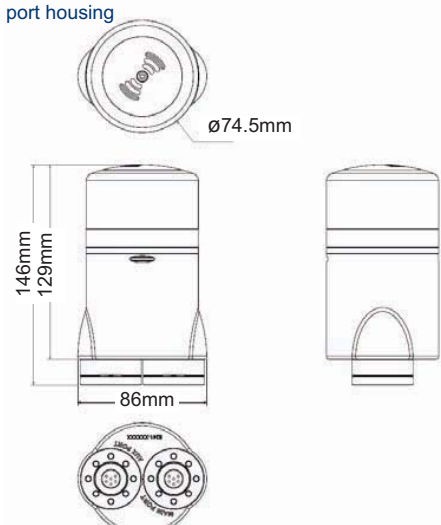

Specifications

Operating frequencies	CHIRP. Maximum bandwidth 500kHz to 900kHz
Beamwidth, vertical	38° at 675kHz
Beamwidth, horizontal	2.3° at 675kHz
Range settings	From 1m [3.2ft] to 100m [320ft]
Scan sectors	User selectable up to 360° continuous
Step speed	0.45°, 0.9°, 1.8° & 3.6° presets
True acoustic zoom	Yes
Instant reversal	Yes
Image measurement	Yes
Inverted head operation	Yes
Power requirements	9V - 36VDC @ 10VA
Data communication	RS485 [twisted pair or modem] RS232 [via modem up to 115kb/s] ArcNet [twisted pair up to 156kb/s]
Communication requirements	Maximum cable length 2500 meters [using ArcNet] Tritech SCU or customer supplied PC/Laptop using standard serial communications, Windows 2000 or Windows XP operating system
Topside	
Software	Tritech "SeaNet Pro" advanced control and logging or low level direct command protocol.
Maximum diameter	
Single Port Option	72mm
Dual Port Option	72mm on body tube and 85mm at base
Maximum height	142mm
Weight in air	
Single Port Option	1.0kg [2.2oz]
Dual Port Option	1.05kg [2.3oz]
Weight in water	
Single Port Option	0.39kg [0.8oz]
Dual Port Option	0.44kg [0.9oz]
Maximum operational depth	4000m [13123ft]
Operating temperature	-10°C to +35°C
Storage temperature	-20°C to +50°C

All specifications are subject to change in line with Tritech's policy of continual product development.

Ref: EDS-SON-006.4



Tritech International Limited
Peregrine Road • Westhill Business Park • Aberdeen
AB32 6JL • United Kingdom

T: +44 (0)1224 744111
F: +44 (0)1224 741771
E-mail: sales@tritech.co.uk
Website: www.tritech.co.uk

Marketed by:



Sea and Land Technologies Pte Ltd

65 Tuas Avenue 1, Singapore 639508
Tel: +(65) 6518 0777 Fax: +(65) 6563 0366
enquiry@sea-landtech.com.sg
http://www.sea-landtech.com.sg