



## Super SeaKing DFP Dual Frequency Profiling Sonar

### Features

- 0.6MHz profiler for use in water containing suspended particles or where longer ranges are required
- 1.1MHz profiler for higher accuracy work at short ranges in clearer water
- Hard Boot protection
- Increased scan rate

### Applications

- Pipeline and trench cross sectional profiling
- Precision positioning of mattresses and rock dumping.
- Storage tank survey
- Underwater surveying of road and rail bridge foundations



The Tritech SeaKing suite of sensors is comprised of an ever increasing range of products that are continually being revised.

The Super SeaKing Dual Frequency Profiling Sonar Head uses the latest technological advances available in transducer design. Using composite transducer technology this sonar offers substantially increased ranges and image resolution.

Utilising side lobe suppression techniques, improved SNR and a reduced beam width. The Super SeaKing DFP provides high quality profile data never before available from a mechanical scanning profiler.

Operating at 0.6MHz and 1.1MHz this new profiler has been designed with a hard boot, which offers increased protection over conventional mechanical scanning profilers.

As part of the SeaKing suite of survey sensors the Super SeaKing DFP can be run simultaneously with a number of SeaKing sensors all communicating over one network. This offers the obvious financial benefit where only one processor is required to run a number of sensors as well as the simplified logistics of running a suite of sensors over one communication link and operated by one control unit.



### Specifications

<b>Operating frequency</b>	600 kHz & 1.1 MHz
<b>Beamwidth</b>	2° Conical [600 kHz]
<b>Beamwidth</b>	1° Conical [1.1 MHz]
<b>Maximum range</b>	80 m [600 kHz]
<b>Maximum range</b>	40 m [1.1 MHz]
<b>Minimum range</b>	0.3 m
<b>Timing resolution</b>	1 mm
<b>Source level</b>	210 dB re 1uPA @ 1 m
<b>Pulse length</b>	20 - 200 microsec
<b>System bandwidth</b>	30 kHz
<b>Scan modes</b>	Combinations of speed and resolution available
<b>Mechanical step sizes</b>	0.45°, 0.9°, 1.35° & 1.8°
<b>Mechanical resolution</b>	0.45°
<b>Scanned sector</b>	Variable to 360°
<b>Continuous 360° mode available</b>	Yes
<b>Sector offset mode available</b>	Yes

#### Mechanical

<b>Overall maximum diameter</b>	110 mm
<b>Maximum length</b>	287 mm
<b>Weight in air</b>	3.5 kg
<b>Weight in water</b>	1.7 kg
<b>Maximum operational depth</b>	4,000 m

<b>Materials</b>	Aluminium alloy-HE30, RPU
<b>Finish</b>	Hard anodised black
<b>Standard connector</b>	Tritech 6 pin with water-block

<b>Connector options</b>	Various upon request
<b>Operating temperature</b>	-10°C to +35°C
<b>Storage temperature</b>	-20°C to +50°C

#### Electrical

<b>Power requirements</b>	18 to 36 VDC @ 10VA
<b>Optional power supplies</b>	9 to 18 VDC and 36 to 72 VDC @ 10VA

<b>Data communication rate</b>	156 kBits/sec
<b>Option</b>	78 kBits/sec
<b>Communication requirements</b>	Twisted pair modem

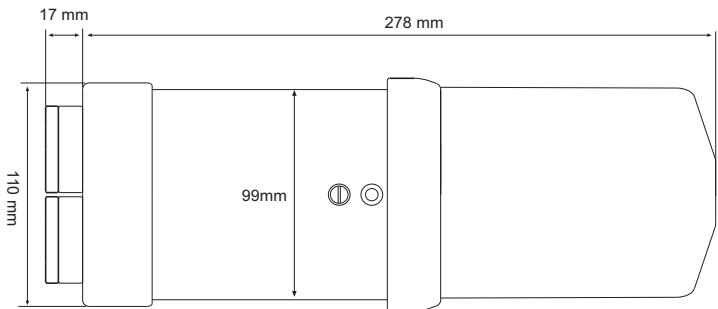

#### Surface Controls and Displays (SeaKing SCU or PC kit)

<b>Display</b>	Seanet Pro compatible SVGA up to 1280 x 1024 x 256
----------------	---

#### Software Features

<b>Range Selection</b>	1 to 80 m
<b>Gain</b>	Full manual and auto controls
<b>Scanned Sector</b>	Fully variable in direction and width to 360°
<b>Resolution Selection</b>	0.45° to 1.8° steps
<b>Head Position and Rotation Offsets</b>	To 1 mm / 0.09° resolution
<b>Lockout Control</b>	
<b>Frequency Switch</b>	
<b>Trigger Mode</b>	Continuous or Manual
<b>Cursor</b>	x-y measurement

- Support for single, dual and quadruple head operations
- Support for all other Tritech sensors - sonar, bathymetric, sidescan and roll sensor
- Time stamped data logging and replay to hard disk
- Interface to Tritech, TSS and Innovatum Pipe and Cable Trackers
- Support for up to four remote RS232 channels for survey data
- Full remote control and data logging via SK-V4 protocol

All specifications are subject to change in line with Tritech's policy of continual product development.

Ref: EDS-PRF-002.6



#### Tritech International Limited

Peregrine Road • Westhill Business Park • Aberdeen  
AB32 6JL • United Kingdom

T: +44 (0)1224 744111

F: +44 (0)1224 741771

E-mail: sales@tritech.co.uk

Website: www.tritech.co.uk

Marketed by:



#### Sea and Land Technologies Pte Ltd

65 Tuas Avenue 1, Singapore 639508

Tel: +(65) 6518 0777 Fax: +(65) 6563 0366

enquiry@sea-landtech.com.sg

http://www.sea-landtech.com.sg