

ARGONAUT-XR

MULTI-CELL DOPPLER CURRENT PROFILER

FEATURES

- 10 cell current profiling
- AutoTide - Additional velocity cell that dynamically adjusts with changing water level
- Pressure
- Temperature
- Internal recorder
- Non-corrosive housing

OPTIONS

- Waves (height, period, spectra)
- Battery power
- Integrated CTD



The PRACTICAL SOLUTION to CURRENT and WAVE MEASUREMENT

The Argonaut-XR offers exceptional value for current profiling applications. Its small size, rugged build quality, and flexible system architecture make the Argonaut-XR very attractive for both real-time operation as well as autonomous deployments.

SonTek's exclusive MultiCell feature allows you to preprogram 10 fixed velocity cells wherever you want, then an 11th dynamic cell can be set to automatically change its position as the water level changes.

The basic autonomous system includes batteries, internal recorder, compass/tilt sensor, pressure and temperature sensors. Adding options such as the SonWave package, or a SeaBird MicroCAT CT sensor, make the Argonaut-XR the centerpiece of a complete oceanographic system.

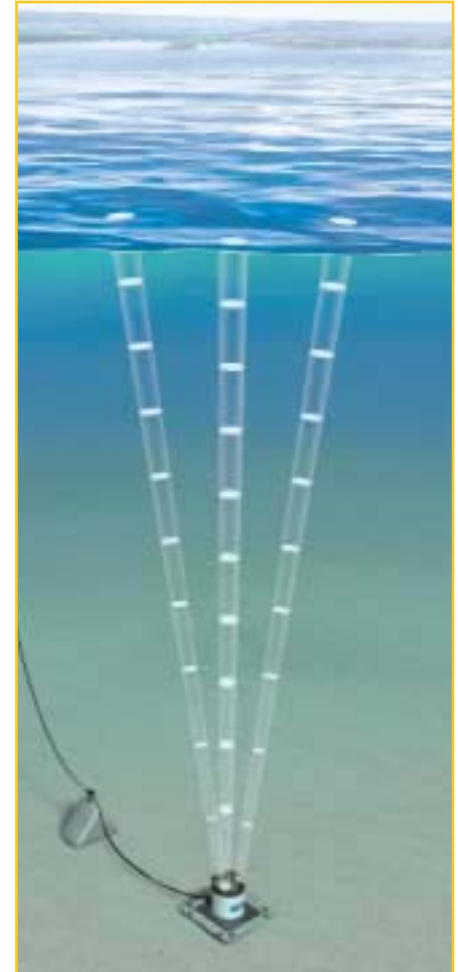

The Argonaut-XR measures water velocities at each of the profiling cells.

The additional dynamic cell adjusts with changing water level.

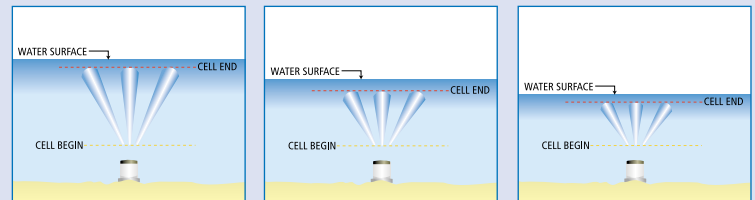

SPECIFICATIONS

Argonaut-XR

Select the Argonaut-XR frequency that meets your range and resolution requirements:

Frequency	Maximum Range*	Resolution
3.0 MHz	6.0 m (20.0 ft)	0.2 m (0.6 ft)
1.5 MHz	20.0 m (66.0 ft)	0.4 m (1.2 ft)
0.75 MHz	40.0m (131.0 ft)	0.8 m(2.5 ft)

* Maximum range may vary depending on environmental conditions.

Water Velocity

- Range: $\pm 6\text{m/s}$ (0.003 ft/s)
- Resolution: 0.1 cm/s
- Accuracy: (0.016 ft/s) $\pm 1\%$ of measured velocity, $\pm 0.5\text{ cm/s}$

Standard Features

- MultiCell feature (10 water velocity cells plus an eleventh automatically adjusting cell)
- Three-beam transducer for measuring 3D water velocity
- Integrated piezoresistive pressure sensor 0.1% accuracy
- Reflected echo intensity output
- SDI-12 (with a limited set of output parameters)
- Mounting plate for easy installation
- RS 232 communication protocol
- ViewArgonaut Windows software for real time data collection, data retrieval, deployment, diagnostics and processing
- Flexible sampling strategies for reduced duty cycle operation and extended deployments of over 1 year
- Internal memory (stores over 20,000 samples)
- Compass/two-axis tilt sensor
- Temperature sensor on exposed titanium pin for fast response

Optional Features

- External battery pack for autonomous operation
- RS422 or RS485 output
- RPT Pressure sensor
- Integrated SeaBird CTD

- SonWave real-time non-directional wave spectra package
- YSI 6820

Temperature Sensor

- Resolution: 0.01°C
- Accuracy: $\pm 0.1^\circ\text{C}$

Compass/Tilt Sensor

- Resolution: Heading, Pitch, Roll 0.1°
- Accuracy: Heading $\pm 0.5^\circ$
- Accuracy: Pitch, Roll $\pm 1^\circ$
- Built-in calibration procedure to compensate for ambient magnetic fields

Physical & Environmental

- Depth rating: 200m
- Dimensions: 15.2 cm (6.0 in.) diameter by 18.0 cm (7.1 in.) height
- Weight in air: 2.5 kg (5.5 lb.)
- Weight in water: -0.3 kg (-0.7 lb.)
- Operating Temperature: -5° to 40°C
- Storage Temperature: -10° to 50°C

Power

- Input power: 7-15 V DC
- Typical power consumption: 0.2 to 0.3 W (continuous operation); 0.01W (stand-by)
- Battery capacity (alkaline): 400 W-hr

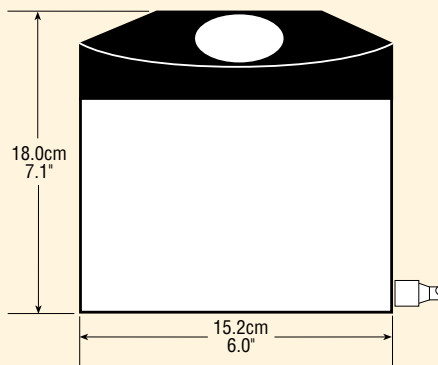
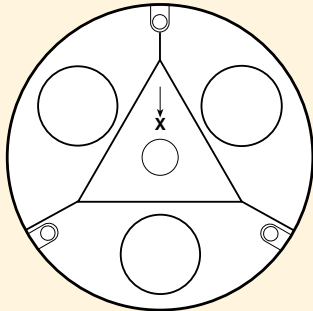

Argonaut-XR



The Argonaut-XR on mounting plate with optional battery pack.



Sea and Land Technologies Pte Ltd

65 Tuas Avenue 1
Singapore 639508
Email: enquiry@sea-landtech.com.sg
Website: http://www.sea-landtech.com.sg

Tel : +(65) 6518 0777
Fax : +(65) 6563 0366

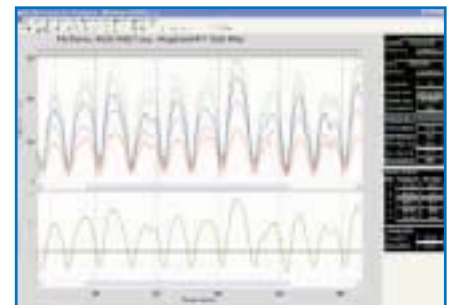

Display multi-cell velocities using SonTek's ViewArgonaut software.

SonTek and Argonaut are registered trademarks of SonTek/YSI, Inc., San Diego CA, USA. Specifications subject to change without notice. SonTek/YSI is an employee-owned company. Argonaut-XR V4, 9/04