



Intelligent Transmitters

Series 1000, 6000 & 9000



RANGES

Absolute	0-15 psia to 0-40,000 psia
Gauge	0-15 psig to 0-200 psig
Differential	0-3 psid to 0-18 psid

FEATURES

- 0.01% Accuracy
- 1 x 10⁻⁸ Resolution
- High Stability and Reliability
- Dual RS-232 and RS-485 Interfaces
- Fully Calibrated and Characterized
- ISO 9001 Quality System – NIST Traceable

APPLICATION AREAS

- | | |
|-------------|-----------------------------|
| Metrology | Oceanography |
| Hydrology | Process Control |
| Aerospace | Energy Exploration |
| Meteorology | Wind Tunnel Instrumentation |

Paroscientific Intelligent Transmitters consist of a Digiquartz® pressure transducer and a digital interface board in an integral package. Commands and data requests are sent via two-way RS-232 or RS-485 serial interfaces. Digital outputs are provided directly in engineering units with typical accuracy of **0.01%** over a wide temperature range. Output pressure is fully thermally compensated using a quartz crystal temperature signal. All intelligent transmitters are preprogrammed with calibration coefficients for full plug-in interchangeability.

Intelligent Transmitters are available in 19 absolute pressure ranges from 15 psia (0.10 MPa) to 40000 psia (276 MPa), 6 gauge pressure ranges from 15 psig to 200 psig, and differential pressure ranges of 3, 6, and 18 psid. Dual RS-232 and RS-485 interfaces allow complete remote configuration and control of all operating parameters, including resolution, sample rate, choice of engineering units, integration time, and sampling requests. Commands include: Single sample and send, synchronized sample and hold, continuous sample and send, and special burst sampling modes.

New and enhanced features include support for both serial loop and multi-drop networking, selectable baud rates up to 115,200 baud, synchronization of measurements with time-based integration, 2 or 4 wire RS-485 transmission distances greater than 1 kilometer, improved high-speed continuous pressure measurements, a power management "sleep" mode, data formatting features, and unit identification commands.

Free software is included for setup, configuration, sampling, display, data logging, and plotting.

The Model 715 displays pressure and temperature data from all Paroscientific Intelligent transmitters that have Dual RS-232 and RS-485 interfaces. The two-line, 16 character, alphanumeric, backlit, liquid crystal display is user configurable with included software. Display functions include pressure and temperature values with engineering units, overpressure warning, tare indicator, user defined text messages, and a horizontal analog bar graph showing percentage of full-scale pressure.

The Model 715 Display will respond to display commands from the Transmitter, a computer, or other serial host on either the RS-232 or RS-485 port. For stand-alone operation, it displays data whenever power is applied to the transmitter.

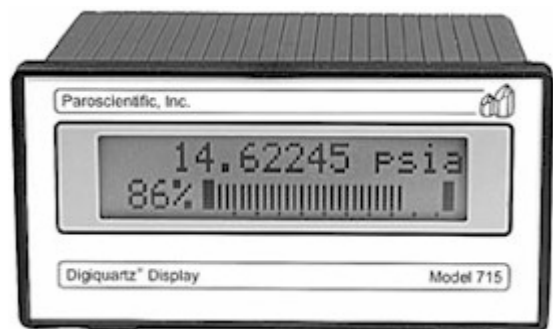

All Digiquartz® Transducers come with a limited 5-year warranty with the first 2 years covered at 100%.

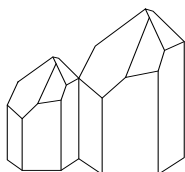

Paroscientific, Inc.
Digiquartz® Pressure Instrumentation



Digiquartz® Pressure Instrumentation

Series 1000



- Ranges Available:
 - 15 Absolute Pressure Ranges:
From 0-15 psia (0.10 MPa) to 0-10,000 psia (69 MPa).
 - 6 Gauge Pressure Ranges:
From 0-15 psig (0.10 MPa) to 0-200 psig (1.38 MPa)
 - 3 Differential Pressure Ranges: 0-3, 0-6, 0-18 psid (0.12 MPa)
- Integral Microprocessor Electronics
- Digiquartz® Transducer with Integral Shock Mount
- Fully Temperature Compensated and Linearized Outputs
- Dual RS-232 and RS-485 Interface
- User Selectable Parameters Include:
 - Resolution, Sample Rate, Engineering Units,
 - Integration Time, Sampling Commands, Software
 - Recalibration Features, and Baud Rate
- Compatible with the Model 715 Display

Series 6000



- Ranges Available:
 - 10 Absolute Pressure Ranges:
From 0-15 psia (0.10 MPa) to 0-500 psia (3.45 MPa).
 - 6 Gauge Pressure Ranges:
From 0-15 psig (0.10 MPa) to 0-200 psig (1.38 MPa)
- Miniaturized Integral Microprocessor Electronics
- Digiquartz® Transducer with Integral Shock Mount
- Fully Temperature Compensated and Linearized Outputs
- Dual RS-232 and RS-485 Interface
- User Selectable Parameters Include:
 - Resolution, Sample Rate, Engineering Units,
 - Integration Time, Sampling Commands, Software
 - Recalibration Features, and Baud Rate
- Compatible with the Model 715 Display

Series 9000



- Ranges Available:
 - 9 Absolute Pressure Ranges:
From 0-1000 psia (6.89 MPa) to 0-40,000 psia (276 MPa).
- Miniaturized Integral Microprocessor Electronics
- Digiquartz® Transducer with Integral Shock Mount
- Fully Temperature Compensated and Linearized Outputs
- Dual RS-232 and RS-485 Interface
- User Selectable Parameters Include:
 - Resolution, Sample Rate, Engineering Units,
 - Integration Time, Sampling Commands, Software
 - Recalibration Features, and Baud Rate
- Compatible with the Model 715 Display

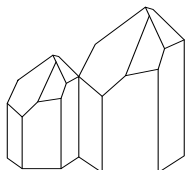

Intelligent Transmitters

Series 1000, 6000 & 9000

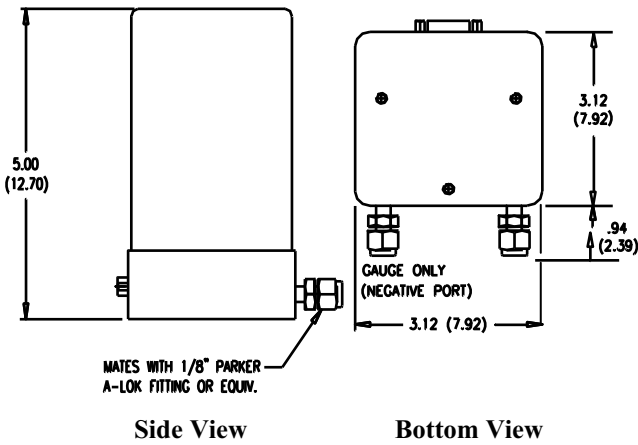

Pressure Performance:	Typically better than 0.01% Full Scale*
Operating Temperature Range:	
Low Pressure and Gauge Ranges (≤ 1000 psi):	-40°C to +70°C
High Pressure Ranges (> 2000 psi):	0°C to +70°C
Barometric Range:	-40°C to +50°C
Differential Pressure Ranges:	0°C to +40°C
Typical Current Consumption at +6 VDC:	16.5 mA
Typical Resolution at 1 sample/sec:	1 ppm
Engineering Units:	8 Standard or User-defined
Baud Rate Selection:	300 to 115200
Overpressure:	1.2 x Full Scale 1000-16B to 18 psia
Weight:	29 oz (822 g) Max
RS-232 & RS-485 Communication:	Compatible with EIA/TIA RS-232 Compatible with EIA/TIA RS-485

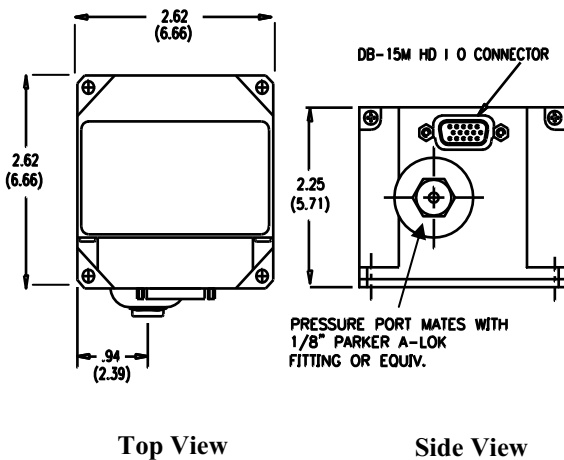

Pressure Performance:	Typically better than 0.01% Full Scale*
Operating Temperature Range:	
Barometric Range:	-54°C to +60°C
Other Ranges:	-54°C to +70°C
Typical Current Consumption at +6 VDC:	16.5 mA
Typical Resolution at 1 sample/sec:	1 ppm
Engineering Units:	8 Standard or User-defined
Baud Rate Selection:	300 to 115200
Overpressure:	1.2 x Full Scale 6000-500A 1 x Full Scale 6000 - 16B to 18 psia
Weight:	15.9 oz (450 g) Max
RS-232 & RS-485 Communication:	Compatible with EIA/TIA RS-232 Compatible with EIA/TIA RS-485

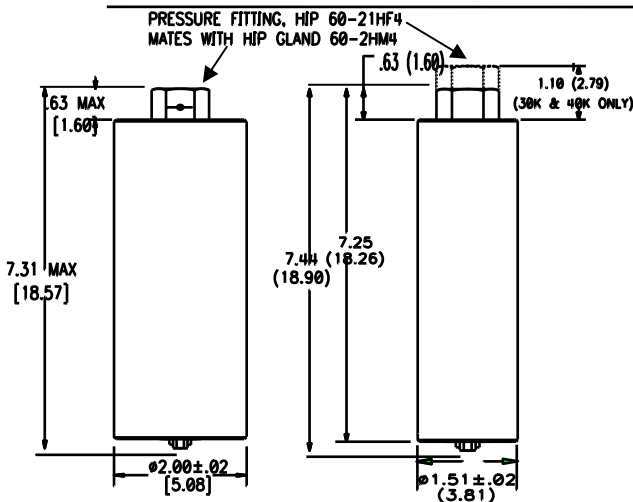

Pressure Performance:	Typically better than 0.01% Full Scale*
Operating Temperature Range:	1K -40°C to +70°C 2K to 10K 0°C to +70°C 15K to 40 K 0°C to +50°C
Typical Current Consumption at +6 VDC:	16.5 mA
Typical Resolution at 1 sample/sec:	1 ppm
Engineering Units:	8 Standard or User-defined
Baud Rate Selection:	300 to 115200
Overpressure:	1.2 x Full Scale 30K & 40K Only- 1.1 x Full Scale
Weight:	2K to 40K - 10.83 oz (307 g) Max 1K - 21.36 oz (606 g) Max
RS-232 & RS-485 Communication:	Compatible with EIA/TIA RS-232 Compatible with EIA/TIA RS-485

Model 9000-1K-101 Other Series 9000 Models

* Consult transducer SCD for detailed specifications.

Dimensions are in inches - parenthesized dimensions are in centimeters.



Digiquartz® Pressure Instrumentation

Pressure Range		Dual RS-232 and RS-485 Interfaces		
PSI	MPa	Series 1000	Series 6000	Series 9000
ABSOLUTE		Ordering Part Number		
0-15	0-0.10	1650-001	1601-00X	
11.5-16	0.08-0.11	1650-101	1600-**	
0-23	0-0.16	1650-002	1602-00X	
0-30	0-0.21	1650-003*	1603-00X*	
0-45	0-0.31	1650-004*	1604-00X*	
0-100	0-0.69	1650-005*	1605-00X*	
0-200	0-1.38	1650-006*	1606-00X*	
0-300	0-2.07	1650-007*	1607-00X*	
0-400	0-2.76	1650-008*	1608-00X*	
0-500	0-3.45	1650-009*	1609-00X*	
0-1000	0-6.89	1650-016*		1620-001*
0-2000	0-13.8	1650-017*		1621-001*
0-3000	0-20.7	1650-018*		1622-001*
0-6000	0-41.4	1650-019*		1623-001*
0-10000	0-68.9	1650-020*		1624-001*
0-15000	0-103.4			1625-001*
0-20000	0-137.9			1626-001*
0-30000	0-206.8			1627-001*
0-40000	0-275.8			1628-001*
GAUGE				
0-15	0-0.10	1650-010*	1610-00X	
0-22	0-0.15	1650-011*	1611-00X*	
0-30	0-0.21	1650-012*	1612-00X*	
0-100	0-0.69	1650-013*	1613-00X*	
0-150	0-1.03	1650-014*	1614-00X*	
0-200	0-1.38	1650-015*	1615-00X*	
DIFFERENTIAL				
0-3	0-0.020	1655-201		
0-6	0-0.041	1655-202		
0-18	0-0.124	1655-203		

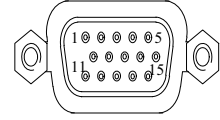

DB-15M Instrument Connector

PIN	SIGNAL
1	CHASSIS GND
2	RS-232 TO COMPUTER
3	RS-232 FROM COMPUTER
4	NOT USED
5	POWER/SIGNAL GND
6	TARE OUTPUT
7	TARE INPUT
8	OVERPRESSURE OUTPUT
9	POWER
10	NOT USED
11	NOT USED
12	RS-485 RX+
13	RS-485 RX-
14	RS-485 TX+
15	RS-485 TX-

Instrument Connector Pin-Outs

DB-15FHD

PIN	SIGNAL
1	CHASSIS GND
2	RS-232 TO COMPUTER
3	RS-232 FROM COMPUTER
4	NOT USED
5	POWER/SIGNAL GND
6	NOT USED
7	NOT USED
8	NOT USED
9	POWER
10	NOT USED
11	NOT USED
12	RS-485 TX+
13	RS-485 TX-
14	RS-485 RX+
15	RS-485 RX-

Model 715 Display
RS-232/RS-485 Connector Pin outs

DB-9F

PIN	SIGNAL
1	CHASSIS GND
2	RS-232 TO COMPUTER
3	RS-232 FROM COMPUTER
4	NOT USED
5	SIGNAL GND
6	NOT USED
7	NOT USED
8	NOT USED
9	NOT USED

Model 715 Display
RS-232 Connector Pin outs

6-POSITION TERMINAL BLOCK

PIN	SIGNAL
1	POWER
2	SIGNAL GND
3	RS-485 TX+
4	RS-485 TX-
5	RS-485 RX+
6	RS-485 RX-

Model 715 Display Terminal
Block Pin outs

X = 1 For Stainless Steel Buffer Tube
 2 For Nylon Buffer Tube
 Add -0 to the Part Number for Oil Filling (Liquid Applications)

- * Add -0 for Oil-Filled
- ** Add -101 for stainless steel, -102 for nylon buffer tube



Sea and Land Technologies Pte Ltd
 65 Tuas Avenue 1
 Singapore 639508
 Tel : (65) 6561 2622
 Fax : (65) 6563 0366

Product defined by Specification Control Drawing. Specifications subject to change without prior notice.
 Manufactured under one or more of the following U.S. Patents: 4,454,770 - 4,455,874 - 4,592,663 - 4,724,351 - 4,751,849 - 4,757,228 - 4,764,244 - 4,831,252 - 4,872,343 - 4,912,990 Other patents pending.