

Thank you for your recent enquiry, we hope you find the following information useful. We look forward to hearing from you if Seaflex can be of service; please do not hesitate to contact us if you require further information or a prompt quotation.

#### FEATURES OF THE 1t IBU:

- All Seaflex Inflatable Buoyancy Units (IBUs) comply with the current offshore standard; **IMCA D016-IBUs**. Units are designed and type tested to a safety factor in excess of the required 5:1 and constructed under **BS EN ISO 9001:2000** controlled procedures independently assessed and certified by **Lloyds Register Quality Assurance**.
- Log Books issued with every IBU contain all details, information and procedures required by IMCA D016-IBUs, and facilitate keeping the required records by the end user.
- Canopy fabric is high tensile PVC coated polyester with HF welded seams for maximum strength. This advanced 'performance fabric' has been well proven over the last ten years and maintains its strength, flexibility and weldability far longer than normal fabrics.
- Circumferential load bearing strops terminate in steel lifting rings for shackling to the load and are contained within welded strop pockets to minimise damage caused by snagging.
- The unique end strops distribute end loads from towing or wave action into the canopy and reduce damage to strop pocket exits. They also allow these bags to be used at higher angles of trim than other manufacturer's products.
- Every IBU is fitted with Pressure Relief Valves to prevent over inflation and dump air under controlled lifting operations; they should only be used for static uplift on underwater objects and must not be used for free ascents through the water column.
- The best materials, good design and meticulous manufacturing make Seaflex IBUs the first choice for end users requiring safety, ease of use and best value for through life cost.

#### COMPONENTS LIST:

COMPONENT PART No	COMPONENT DESCRIPTION	COMPONENT DESCRIPTION	QUANTITY PER BAG
SFX-1IBU/1	Canopy	PVC coated HT polyester 2x2 Panama 1010gms/m. HF welded seams.	1
SFX-1IBU/2	Masterlinks	Fram 11B4 SWL 1.7t SF 5:1	2
SFX-1IBU/3	Shackles	1.0t Galvanised Screw Pin Bow Shackles US FED Spec. RR-C-271 S.F. 6:1	2
SFX-1IBU/4	Circ Strops	Polyester Sling Webbing – 50mm	2
SFX-1IBU/5	Link Strop	Polyester Sling Webbing – 50mm	1
SFX-1IBU/6	End Strops	Polyester Sling Webbing – 50mm	2
SFX-1IBU/7	¾" Globe Valve filling & discharge	Non corrosive, quarter turn on/off Terminates ¾" BSP male thread	1
SFX-1IBU/8	Pressure Relief Valves	A10	2

# SEAFLEX STANDARD PRODUCT

## 1t INFLATABLE BUOYANCY UNIT (IBU)

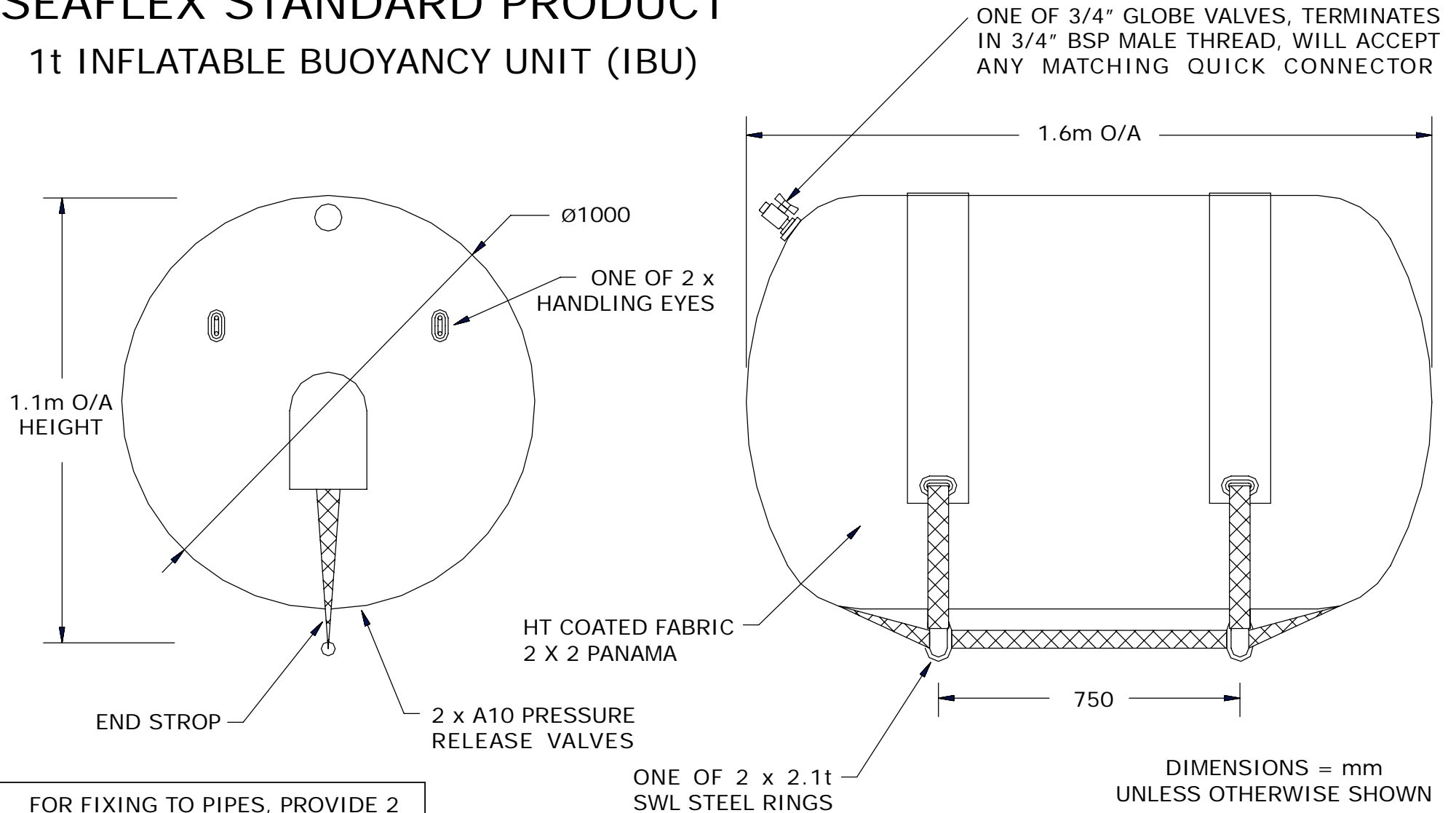

FOR FIXING TO PIPES, PROVIDE 2 ATTACHMENTS AT CENTRES SHOWN

THE INTELLECTUAL CONTENT OF THIS DRAWING IS THE COPYRIGHT OF SEAFLEX LTD. CONTENTS ARE ACCURATE AT TIME OF GOING TO PRESS, BUT MAY CHANGE WITHOUT NOTICE

IBU'S SHOULD BE USED FOR LOADS ON THE SURFACE OR SEABED; NOT FOR LIFTING UPWARDS THROUGH THE WATER COLUMN.  
**MAXIMUM INCLINATION = 20°**

**1t IBU**

Drg. No. 160702/B Issue A

**SEAFLEX Ltd**

SAMUEL WHITES, COWES, ENGLAND, PO31 7RA  
TEL: +441 983 290 525 FAX: +441 983 290 853